

WARNING TAPE REEL LIZARD S. 280



**ADVANCED FLUID
MANAGEMENT SOLUTIONS**

NEW
up to 28 m



RAASM warning tape reels are the ideal solution for all those situations where it's necessary or mandatory to delimit the dangerous working areas both for the operators and the external people.

There are many applications examples: fuel loading on tanks in service stations or goods and luggage unloading in airport.

The warning tape reel is designed to satisfy the main RAASM quality characteristics in terms of structure and durability.



SPEED CONTROL

The versions listed below come with clutch so that tape rewinding can be performed at a controlled speed. They are marked by the **SPEED CONTROL** dataplate.





P/N	Tape color	Length	Weight	Cover colors
92800.010	White - Red	16 m	5,7 kg	RAL 7035
92800.020	Yellow - Black	16 m	5,7 kg	
92800.028	White - Red	28 m	6,6 kg	RAL 1004
92800.029	Yellow - Black	28 m	6,6 kg	

P/N	Tape color	Length	Weight	Cover colors
92840.010	White - Red	16 m	6,1 kg	RAL 7035
92840.020	Yellow - Black	16 m	6,1 kg	
92840.028	White - Red	28 m	7,0 kg	RAL 1004
92840.029	Yellow - Black	28 m	7,0 kg	

Overall dimensions of the delimitation tape

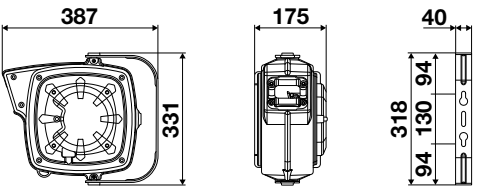
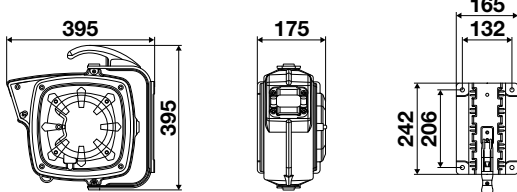
	Width	40 mm
	Thickness	1,5 mm
	Length	16 - 28 m

Overall dimensions without bayonet bracket (mm)	Overall dimensions with bayonet bracket (mm)	Packaging (mm) W x D x H
		 440 x 195 x 485  No. 40 packages per pallet

(W: width - D: depth - H: height)

ACCESSORY FOR WARNING TAPE REEL

P/N 89003

Bayonet bracket, lets you easily move the tape reel within the various workstations.



P/N 89003

TYPE OF INSTALLATION

Fixed and swivelling



RAASM S.p.A.

36022 S. ZENO DI CASSOLA (VI)
Via Marangoni, 33 - ITALY

Export department Tel. +39 0424 571130 - Fax +39 0424 571135
Technical department Tel. +39 0424 571150 - Fax +39 0424 571155

www.raasm.com



Scan for
enter the site



WRFVAN-GB
Rev. 00